

# L-700 Spindle Alignment System

A powerful spindle alignment tool offering high accuracy and simple setup.



**HAMAR  
LASER**®

Geometric Alignment Laser Systems

# High Accuracy, Easy Setup

## Reliable Alignments, Quick Results

The L-700 Spindle Alignment System is a flexible, easy to use alignment tool that has become the workhorse of the industry.



### **L-700 Laser**

The L-700 is a Class II solid-state diode laser with a visible beam that is user-adjustable to be concentric to the center of its mounting stud or the rotation axis of the spindle in which the unit is mounted. The operating range is up to 30' (up to 100' with the L-701).



### **T-261A 4-Axis Spindle Target**

The T-261A 4-Axis Spindle Target has the most angular sensitivity of any Hamar Laser target. It reads both center and angle (pitch and yaw) simultaneously, allowing a real-time display of alignment. It has a resolution of .00002" in center and .00002"/ft. in angle.



### **R-358 Computer Interface**

The R-358 computer interface provides high accuracy (.00002" resolution) for downloading live target data into a computer. Make the system wireless with optional R-359 Wireless Computer Interface and A-908 IR Receiver.

## Benefits

### **0.5 Micron Resolution Improves Part Quality**

The L-700 Spindle Alignment system has a centering resolution of 0.5 microns (.00002") and angular resolution of .00002"/ft. Combined with software to correct mounting errors, the system produces a very accurate alignment; less than .0001" under good environmental conditions. This extremely high level of accuracy can dramatically improve machine performance and reduce scrap rates.

### **Live Data Speeds Alignment, Reduces Downtime**

The L-700 significantly speeds machine alignment by simultaneously checking the vertical and horizontal center and angle readings, and providing live alignment data, so without changing the setup, alignment errors can be quickly and easily fixed. The software also speeds up the alignment by providing shim values and moves for spindle box alignments, using large, color graphics.

### **Misalignment Data in 10 Minutes**

The L-700 Spindle Alignment System is so easy to set up that you can have a quick measurement of misalignment data in 10 minutes. The Windows-based software speeds setup and data taking and even corrects for mechanical mounting errors! It also provides a large color graphical display of the misalignment in all 4 axes.

### **Saves Money on Master Parts and Pallets**

Since the Windows 95/98 Spindle8 software corrects mounting errors, you will no longer need to spend \$50,000+ on master parts that meticulously replicate the desired part. All that is needed is a fixture with the correct hole location and the system does the rest. This significantly reduces master part and pallet capital requirements.

### **Single or Dual Spindle Alignment Capability**

With the addition of an extra laser, computer interface and 4-axis target, the L-700 Spindle Alignment System can also handle complex multiple spindle applications. Our Spindle 8 Software can handle both sets of laser systems at the same time.

### **Patented 4-Axis Target**

The L-700 Spindle Alignment System's 4-axis target measures both the horizontal and vertical center and angular reading simultaneously. This creates a powerful tool for aligning a spindle to a master part, or tailstock or sub-spindle to the headstock on a lathe.



# For Spindle and Lathe Alignment

Hamar Laser's patented 4-axis L-700 Spindle Alignment System is a powerful alignment tool that offers unparalleled accuracy, easy setup and significant savings in alignment maintenance time. For over 10 years, the L-700 System has been helping companies reduce tooling costs and scrap rates while increasing their productivity and profitability.

The L-700 Spindle Alignment System features 4-axis, live data output, so users can align machines quickly and accurately — up to 70% faster than with conventional methods like indicators, alignment bars or interferometers. With a resolution of 0.5 microns (.00002") and large color display computer graphics, the L-700 is the ideal solution to all your spindle alignment needs.

## Typical applications include:

- Transfer-line spindles
- Turning centers (cylindrical, OD/ID grinders, lathes)
- Rotary-dial machines
- Twin-barrel extruders
- Boring bars

The L-700 Spindle Alignment System has been helping auto industry build quality vehicles for over 10 years.

Our Windows 95/98/ME software is unparalleled for clarity and functionality. For aligning transfer-line spindles and rotary-dial machines, our comprehensive Spindle8 software is a powerful tool to speed and document alignments. With over 10 years of transfer-line experience built into the program, Spindle8 allows you to complete spindle alignments in record time, and, when completed, present a professional, color report to management.

When performing lathe alignments, Read8 is the ideal software to help you eliminate mounting errors and provide a live 4-axis alignment screen to help speed alignments. The software also aids in setup by eliminating the need to perfectly center the laser beam to the spindle rotation axis.



## Features

- Simple fixturing for mounting the laser and target.
- Center resolution of 0.5 microns (.00002") and angular resolution of .00002"/ft.
- Live measurement data in 4 axes (vertical and horizontal angle and center).
- Wireless communication with our new R-359 Wireless Interface.
- Windows 95/98 based software with large, color graphics.
- Software corrects mounting errors and calculates shim values.
- L-700 mounts in the spindle to project its axis of rotation out to 100'.
- Vertical and horizontal controls for both angle and center for adjustment of laser to spindle's precise axis of rotation.
- Laser runs for up to 8 hours on a standard, replaceable 9-volt battery.
- Compact and rugged (4"L x 2.9"H x 1.75"W).
- Only needs 10" of space between spindle and master part.

# Transfer Lines

One of the biggest problems with transfer lines is broken taps, drills and reams which can stop production. A big factor causing broken tools is poor angular alignment, especially for taps. When a tap tries to enter a hole and the angular alignment is poor, it results in premature tool wear and breakage.

The critical alignment of a transfer line machine is the axis of rotation of the spindle to the master part or pallet. A .500" stud on the laser is inserted into the spindle chuck and the laser beam is aligned to the axis of rotation of the spindle. The spindle axis of rotation is then projected out to the master part or pallet, where the 4-axis target is used to measure the misalignment of the spindle.



## Automaker Saves Millions

*A "big three" auto manufacturer's misaligned transfer lines were breaking one tool every 50 parts. After using Hamar's L-700 Spindle Alignment System the breakage rate was reduced to one in every 6,000 parts — an 11,900% improvement! The company was ultimately able to save \$1.5 million annually in reduced tooling costs and increased production by 20 engines per day on just one line alone!*

## How It Works

- 1 Straightness and flatness of the ways are checked and fixed, if necessary.
- 2 Spindle axis of rotation is checked for parallelism to the travel of the spindle head and fixed, if necessary.
- 3 The wing base and spindle box assembly is checked to see if the spindle axis of rotation is centered and squared to the master part or pallet and fixed, if necessary.



**Spindle8 – Machine Setup Screen.** Enter machine dimensions for accurate shim calculations.



**Spindle8 – Laser Qualification Screen.** Aligns laser to spindle axis of rotation.



**Spindle8 – Way Straightness Screen.** Quick check for vertical and horizontal way straightness.



**Spindle8 – Data Taking Screen.** Uses NORMIN procedure to eliminate mounting errors.



**Spindle8 – Spindle Box/Wing-Base Misalignment Screen.** Select Angle I or II for spindle-axis parallelism alignment.



**Spindle8 – Final Alignment Screen.** Align spindle box or wing-base assembly to master part.

# Other Applications

## Turning Centers

The critical alignment of a lathe or other turning-type machine is the axis of rotation of the spindle to the tailstock, sub-spindle, turret or tool holder. Conventional methods are cumbersome, time consuming and practically useless on large lathes.

The L-700 vastly simplifies the task by inserting the laser right into the spindle chuck. Using the T-261 target, the laser is aligned to the spindle axis of rotation and is projected out to 100'.

This becomes the reference from which the ways, toolholder and tailstocks can be measured and aligned, allowing the entire length of even the largest lathes to be quickly and easily aligned without changing setups. This is of particular value with large lathes where alignment bars are not practical.

## Large Rotary-Dial Machines

Most rotary dial machines make small, high-tolerance parts and require very accurate alignments. The critical alignment of a rotary-dial machine is the axis of rotation of the spindle to the sub-spindle or part holder.

Similar to transfer line alignment setup, a .500" stud on the laser is inserted into the spindle chuck and the laser beam is aligned to the axis of rotation of the spindle. The spindle axis of rotation can then be projected out to the part holder or sub-spindle, where the 4-axis target measures misalignment of the spindle head for straightness, squareness to the part holder and parallelism to the ways.

## Twin-Barrel Extruders

Using a combination of laser and target from two systems, Hamar Laser has put together a package that works exceptionally well for twin-barrel extruders. It uses the L-700 Spindle Laser and the A-510 2-Axis Self-Centering Target to align twin-barrel extruders to within .0005" in 30 feet.

If the twin-barrel is under construction, the system can be used to align each section of the barrel. If the extruder is already installed, the target can be inserted into the barrel and positioned over adjustment points. The readout displays the misalignment dynamically, or Read8 records and plots straightness.



**Read8 – Offset Screen Showing Spindle Alignment Mode.** Uses NORMIN procedure to eliminate laser and target mounting errors.

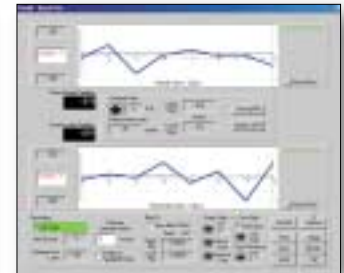

**Read8 – Quick Plot Screen.** Plots vertical and horizontal straightness as well as parallelism between axes.



**Spindle8 – Box/Wing-Base Misalignment Screen.** Select Angle I or II for spindle-axis parallelism alignment.



**Spindle8 – Final Alignment Screen.** Align spindle box or wing-base assembly to master part.

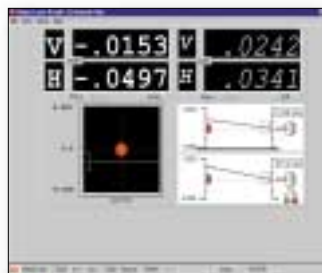

**Read8 – Standard Plot Screen.** Shows horizontal and vertical misalignment with live graphics.



**Read8 – Quick Plot Screen.** Plots vertical and horizontal straightness as well as parallelism between axes.



# Specifications

## L-700 Spindle Alignment Laser

### L-700 Spindle Alignment Laser

<b>Mounting Stud</b>	.500" (12.7mm) diameter is standard Stud can be customized
<b>Weight</b>	18 oz. (510g)
<b>Material</b>	Durable design withstands shop floor environment Mounting Stud: 440C stainless steel, RC54-58 hardness Case: Anodized Aluminum
<b>Laser</b>	CLASS II, < 1 mw
<b>Power</b>	9-volt battery, replaceable, 8-hour life
<b>Power Supply</b>	Rechargeable battery pack (8 hour life)
<b>Effective Beam Adjustment Range</b>	L-700: Up to 30' (9 meters) – measurements can be taken to 100' L-701: Up to 100' (30 meters)
<b>Initial Beam Alignment</b>	.0005" (.013mm) Center .0005"/ft (.042mm/m) Angle
<b>Beam Stability</b>	.0001"/hr/°F (.002mm/hr/°C) Centering .0001"/ft/hr/°F (.005mm/M/hr/°C) Squareness
<b>Adjustment Resolution</b>	.0001" (.003mm) Center .0001"/ft (.008mm/M) Angle
<b>Beam Adjustment Range</b>	±.010" (.25mm) Center L-700: ±0.25 Degrees Angle L-701: ±0.01 Degrees Angle
<b>Dimensions</b>	4"L (101.6mm) × 2.9"H (73.7mm) × 1.75"W (44.5mm)

### T-261A 4-Axis Spindle Target

<b>Weight</b>	14 oz. (400g)
<b>Material</b>	Mounting Stud: 440C Stainless Rockwell RC54-58 hardness Case: Aluminum
<b>Cable Length</b>	10 feet (3.05 meters)
<b>Connector</b>	15-pin connector
<b>Target Cell Concentricity</b>	±.0005" to mounting stud of target
<b>Lens Axis Squareness</b>	±.0005"/ft. (.042mm/meter) to rear of target
<b>Resolution</b>	.00002" (.0005mm) Center (when used with R-358) .00002"/ft (.002mm/M) Angle (when used with R-358)
<b>Range</b>	±.060" (+/- 3.8mm) Center ±0.5° Angle
<b>Cell Linearity</b>	Within 5% of reading
<b>Mounting Dimensions</b>	.500" (12.7mm) diameter concentric mounting stud, replaceable

### R-358 Computer Interface

<b>Resolution</b>	.00002" (.0005mm)
<b>Size</b>	3.33"W × 1.20"H × 5.25"D (84.6mm × 30.5mm × 133.4mm)
<b>Weight</b>	8.8 oz.
<b>Power</b>	3.5V, 1350 mAh lithium ion rechargeable battery
<b>Battery Life</b>	8 hours continuous operation

### L-700 Spindle Alignment Laser

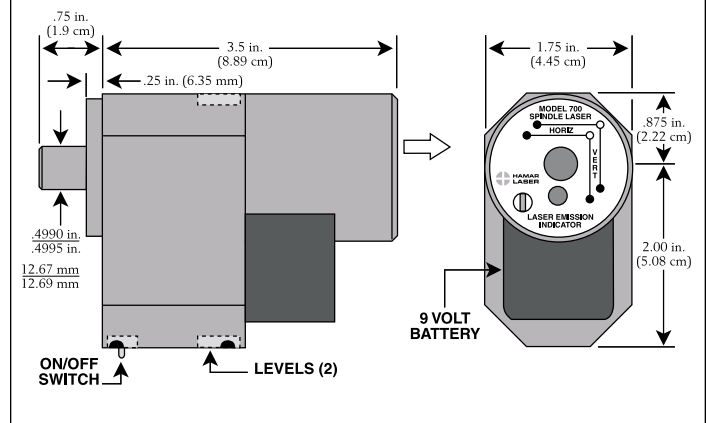

### T-261 4-Axis Spindle Target

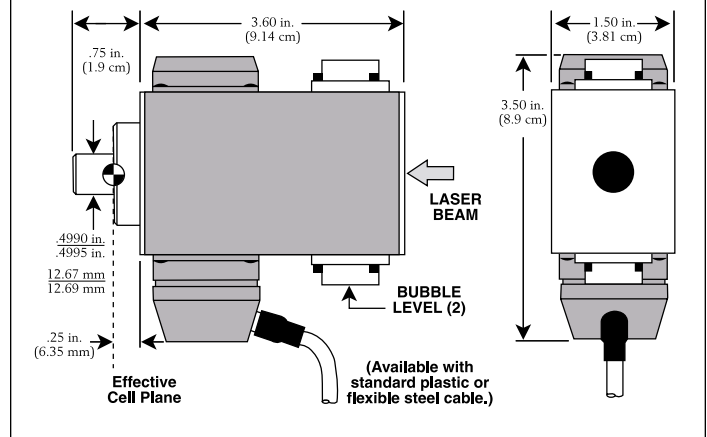

**Hamar Laser Instruments, Inc.**  
5 Ye Olde Road, Danbury, CT 06810  
Phone: 800.826.6185 • Fax: 203.730.4611  
E-mail: sales@hamarlaser.com  
www.hamarlaser.com